

TURNSTILE WITH AUTOMATIC HAND DISINFECTION SYSTEM

The issue of hand disinfection is becoming essential task that requires the involvement of personnel for constant monitoring the disinfection process. To simplify this, has developed a complete TWIX-M-HD solution for automatic hand disinfection and access control.

Smart system and contactless sensors control the entire disinfection cycle of both hands simultaneously. TWIX-M-HD automatic disinfection system completely excludes the possibility of a person passing through a turnstile until complete disinfection cycle of both hands. The installation of both hands. The installation of our comprehensive solution TWIX-M-HD eliminates the need for additional monitoring personnel at building entrances during a pandemic. Moreover TWIX-M-HD-TFR is absolutely all in one: disinfection hands control, wearing protective mask check, measuring temperature.

TECHNICAL SPECIFICATIONS

Power	55W (turnstile) + 5W(disinfection unit)
General dimensions (with disinfection unit)	1000x1252x785
Housing	Brushed/Polished SS AISI 304; Brushed/Polished SS AISI 316 Powder coated RAL
Sanitizer tank capacity	5 lt
Passage capacity (1 sanitizer tank)	4-30 ml/1 pass
Sanitizer liquid type*	~100 mPa.s, 20

*specifications of sanitizer liquid should be considered additionally

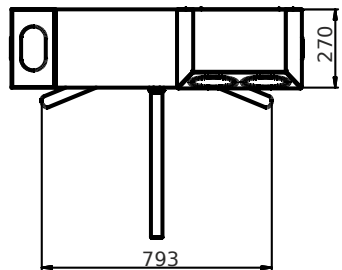
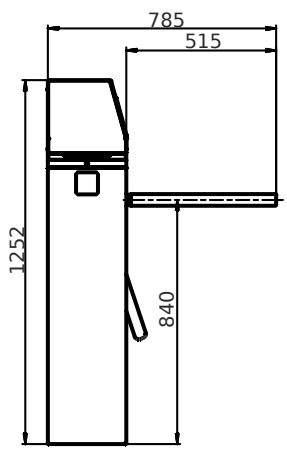
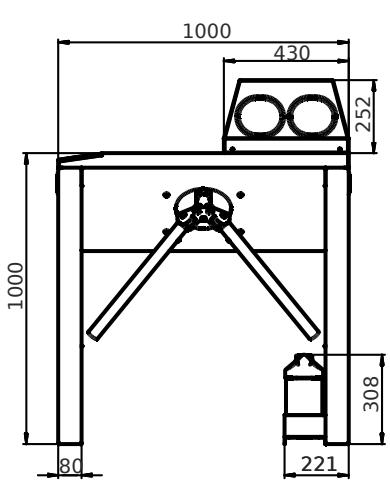
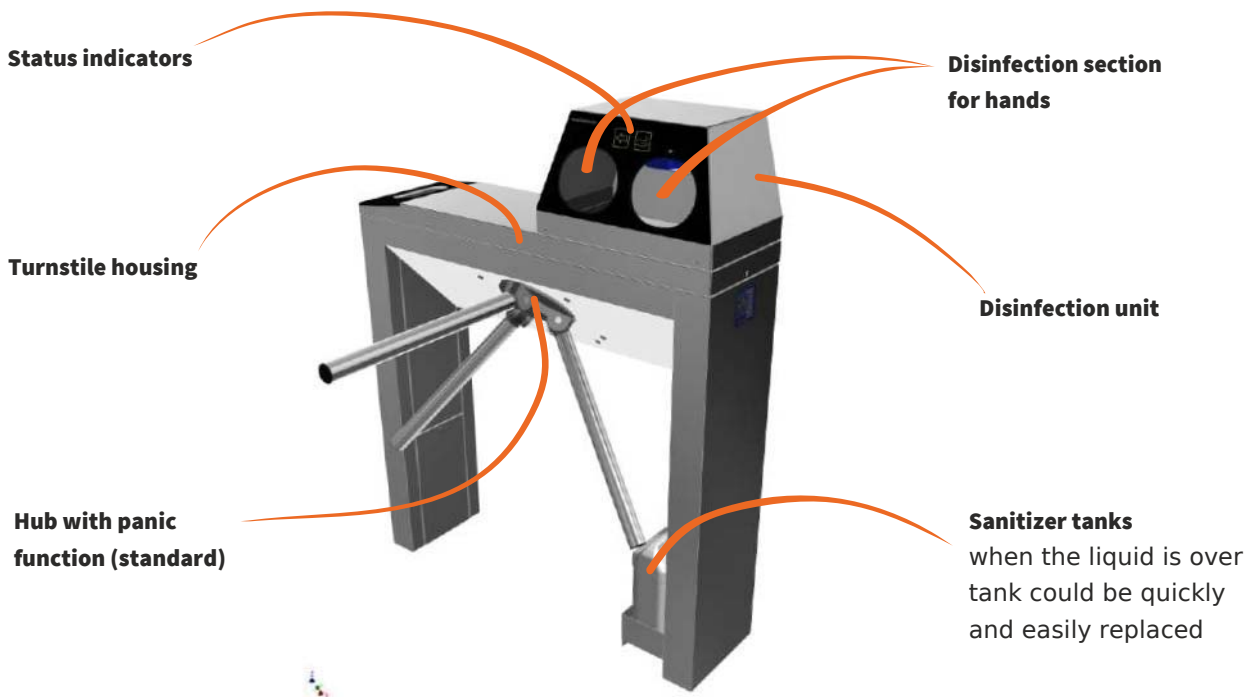



An automatic hand disinfection sprays a sanitizer when a person places their hands in the disinfection unit. In the lower part of the turnstile body there is a 5 liter tank with sanitizer liquid. The sanitizer liquid is extracted from the reservoir by vacuum pumps and sprayed onto the hand from several points. The disinfecting unit is made of stainless steel.

During the disinfection process, the sensors monitor the presence of both hands in the disinfection unit. Disinfection process is fully controlled by smart system.

**ACCESS TO THE TERRITORY ONLY AFTER DISINFECTION.
SMART AUTOMATIC CONTROL OF HANDS DISINFECTION.**

The disinfection system is integrated with the turnstile. Thus, if a person does not complete the full disinfection cycle, the turnstile will remain blocked. Status indicators are symbols that are located on the body of an additional hand disinfection unit. In standby mode, the indication glows red.

After a person has disinfected his hands, a green arrow will light up, indicating that the turnstile is open for one person to pass. Otherwise, a red signal will light up urging you to disinfect your hands.



ADVANTAGES OF TWIX-M TURNSTILE

Automatic hand disinfection system operates in conjunction with the Twix-M tripod turnstile. Twix-M turnstile has a number of advantages that allow it operate reliably and smoothly, see below the main advantages of Twix-M turnstile.

Features of Twix-M turnstile:

- Bi-directional motorized tripod turnstile with panic / bar drop-arm function
- Integration with any type of access control and ID systems
- Low power consumption
- Panic / bar drop-arm function with automatic reset
- Whisper quiet, low noise operation
- Optional indoor or outdoor housing types
- Wide range of accessories
- Availability of a back up battery connection
- Complete supply set as a standard

Standard set of Twix-M turnstile:

- 4 LED indicators
- Wired remote control
- Supply of backup battery power connection
- Anti-panic function with automatic reset (drop arm function)

Options for Twix-M turnstile:

- System to detect symptoms of virus
- Occupancy control system
- Converter (VTR-E/485) RS485 to Ethernet
- TWIC wireless touch control panel (WFRC-207)
- Randomization module
- Counter of passes
- Integration of non-standard validation equipment (RFID, Barcode, QR, Fingerprint, Coin and Token acceptors etc.)
- Heating function for external installation (for cold climates)
- Cooling system
- Tripod Twin modification is available
- Dummy housings can be mounted adjacent to tripod turnstile



ADDITIONAL EQUIPMENT FOR YOUR SAFETY

Occupancy control and people counter system

Occupancy control and people counter system was developed to prevent the spread of the disease. In order to prevent the spread of the disease number of people who can be present in stores simultaneously should be limited. Therefore, we came up with turnstile solution which will enable you to control number of people coming in and out of stores daily.



TWiC

TWiC manages and controls large group of turnstiles and road blockers. The user friendly 8" touch screen display graphics requires minimal training for proficiency in navigating the various pages, remotely controlling the lanes and understanding the real time feedback such as alarm events when unauthorized access is detected.



Card reader/Card collector

Card readers/Card collectors are designed for installation as a part of an access control system for enterprises, administrative facilities, banks and other sites. Elegance, lightness and simplicity make this model very popular as part of access control system.

Systems to detect symptoms of virus

Systems to detect symptoms of virus is special solution for authorizing access depending on persons state of health. More specifically, such system enables to limit access of people with suspected disease symptoms such as high temperature. Speed gates with special integrated authorization system performs face identification and monitors body temperature Such solution can be widely used in public places like hospitals, airports, border control zones, etc.



