

# ELECTROMECHANICAL SWING GATES

## Gate TS 15

Swing gates are used in objects of various architectural character. and thanks to the large number of dimensions available can be used them also as transitions for disabled.

As in the case of turnstiles (tripods), the gates can be controlled via a manual panel or various types of access control systems.

Swing gates are often used to complement other types of gates to ensure full functionality of the crossing and pedestrian traffic control.

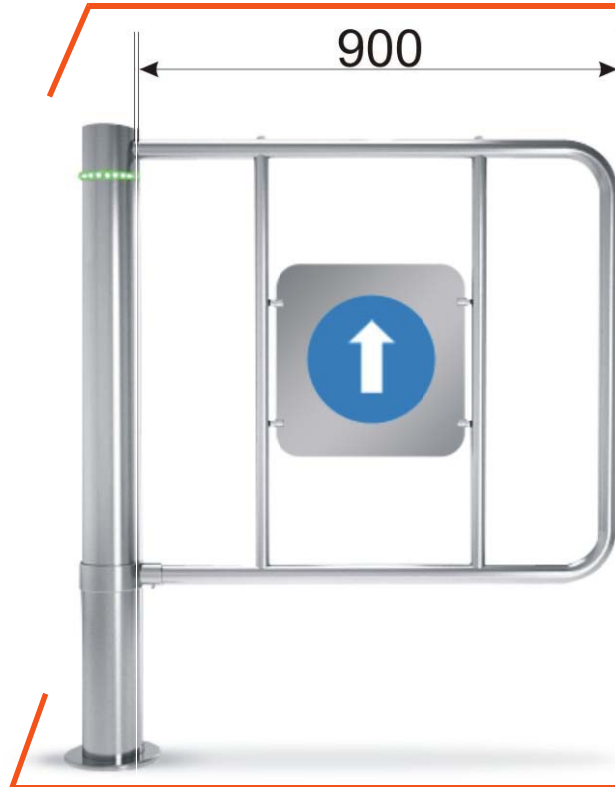

**650/900**  
mm  
PASSAGE WIDTH

**IP 41-65** \*  
PROTECTIVE LEVEL

### Advantages

- Two-way electromechanical swing gate
- High quality at an affordable price
- Steadfast housing suitable for high traffic areas
- Can be connected with any type of access control systems
- Low power consumption
- Low noise system operation
- The gate is adapted to be installed indoor

### Possible variants

- Gate 15 Gibont 900 mm arm

### Standard

- Pictogram LED display, Green color- transition status, Red color- no passage
- power connection with a battery (voltage backup in the event of a power failure)

### Options

- Any additional devices upon request (e.g. passage counter, RFID/ Proximity/ BioMetric Readers, coin acceptor, Push button, barcode and QR-code reader)
- Electronic module that provides automatic anti-panic function upon power failure

# ELECTROMECHANICAL SWING GATE TS 15

## TECHNICAL SPECIFICATION

Width, mm	900 standard
Diameter, mm	90
Height, mm	1000
Weight, kg (not more)	20
Mechanism	Electromechanical

### Controlled by:



access control system



manual control

Available Housing Options:  
 Brushed Steel AISI 316  
 Polished Steel AISI 304  
 Polished Steel AISI 316  
 Powder Coated Steel RAL

When power goes OFF both directions are free.

### Electrical specifications:

- Voltage:
  - AC 100-240V, 50/60Hz
  - From a DC 12V
- Maximum power consumption 55W per pass;

### Materials

Standard Housing	Brushed Stained Steel AISI 304
------------------	-----------------------------------

### Installation areas:

- Governmental institutions
- Military Bases
- Nuclear Power Plants
- Productions Sites (Industrial Plants)
- Commercial areas
- Financial Institutions
- Airport
- Business (Office) Centers
- Hotels
- Sport Complexes
- Urban areas

### Preparations for assembly:

- Foundations dimensions:
  - Height: 300mm
  - Length: 325mm
  - Width: 325mm
- Cables coming from the foundation must have at least 1m of reserve
- Communication cable 1x twisted pair FTP 8X0,22 2(0,5mm)<sup>2</sup>
- Power Cable 3x1,5mm<sup>2</sup>

# ELECTROMECHANICAL SWING GATE TS 15

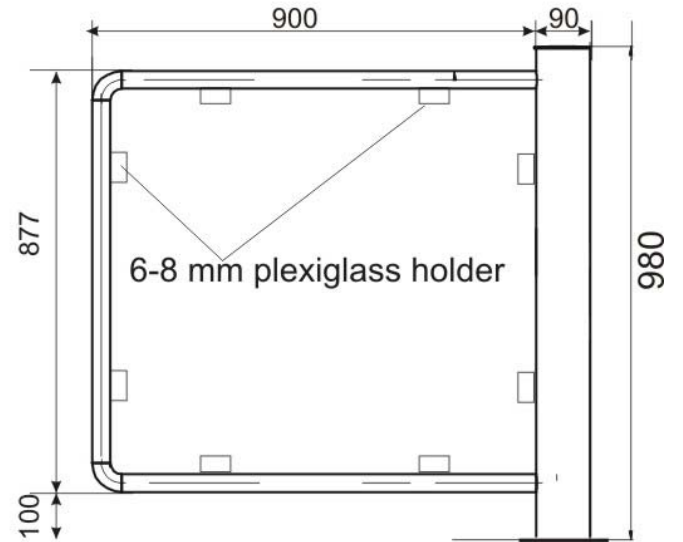
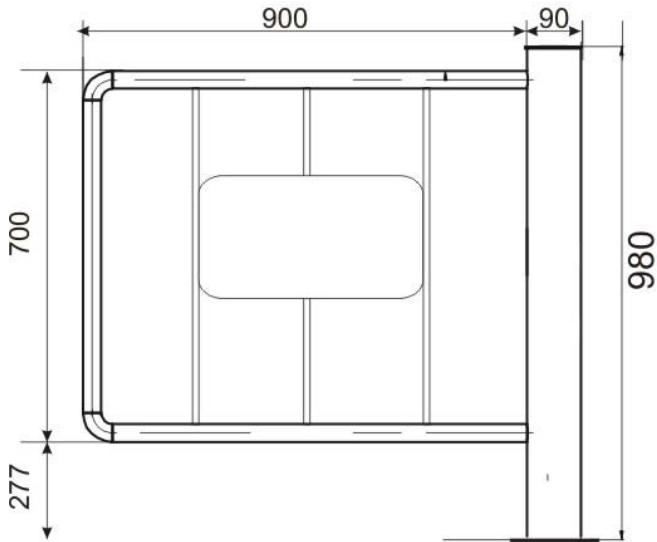

**CartPoland**

Wólka Mińska ul. Olszowa 5 ,05-300 Mińsk Mazowiecki  
office@cartpoland.pl | www.cartpoland.pl  
www.bramkiobrotowe.eu | www.bramkiobrotowe.com

