

TRIPOD TURNSTILE

TWIX TWIN - M

Twin turnstile is one more solution from tripod series. This model is widely applicable both for sophisticated interiors of business facilities, as well as operating at high intense mode. Being developed on the basis of Twin turnstile, this modification provides two passing lanes. Such design serves to be a good solution in purposes of project's budget optimization and better spacing at installation site. Anti-panic /drop-arm function is provided within this type of motorized turnstile. Mounting brackets for card readers' installation are placed under the top by default. Modification for outdoors installation is also available.



THE MOST ELEGANT TRIPOD WITH FIRM 2 LEGS TO STAND ON



Advantages

- Bi-directional motorized tripod turnstile with drop-arm function
- Successful combination offering high quality at an affordable price
- Stable and Robust housing suitable for high traffic areas
- Can be integrated with any type of access control system
- Low power consumption
- Anti-panic function with automatic return to the starting position
- Whisper quiet, low noise operation
- Turnstile housing can be adapted for both indoor and outdoor installations
- Integrated RFID reader bracket under top glass
- Can be mounted on the Frame M mobile platform

Standard

- 2 location LED indicators
- Wired remote control
- Supply of backup battery power connection
- Anti-panic function with automatic reset

Options

- Preparation for various third-party devices (e.g. passage counter, RFID/Proximity/BioMetric readers, coin acceptor, push button, barcode and QR-code reader)
- Heating function for external installation (for cold climates)
- Electronic module that provides automatic anti-panic function upon power failure
- Tripod Twin modification is available
- Dummy housings can be mounted adjacent to tripod turnstile

* first figure is standard, all other available upon request.

Technical Specifications:

Unit width, mm	1004
Unit length, mm	1520
Unit height, mm	1000
Weight, kg (not more)	90
Mechanism	Motorized

Controlled by:



access control system;



manual control

When power goes OFF both directions are free.

Electrical Specifications:

- Voltage:
 - from the AC (100-240)V, 50/60Hz;
 - from a DC source 12 V;
- Maximum power consumption 55W per pass;

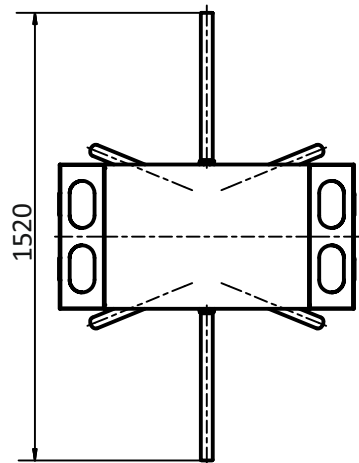
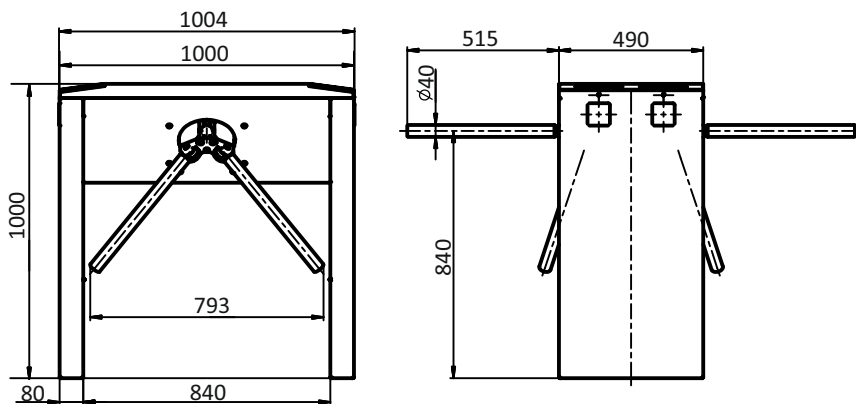

Materials

Standard housing	Brushed SS AISI 304
Available housing	Brushed SS AISI 316 Polished SS AISI 304 Polished SS AISI 316 Powder coated RAL
Tripod hub	Cast aluminum with painted grey finishing

Installation areas:

- Governmental Institutions
- Military Bases
- Nuclear Power Plants
- Production sites (Industrial Plants)
- Commercial areas
- Financial institutions
- Airport Premises
- Business (Office) Centers
- Hotels
- Sport Complexes
- Recreation areas
- Urban areas
- Education Institutions
- others